

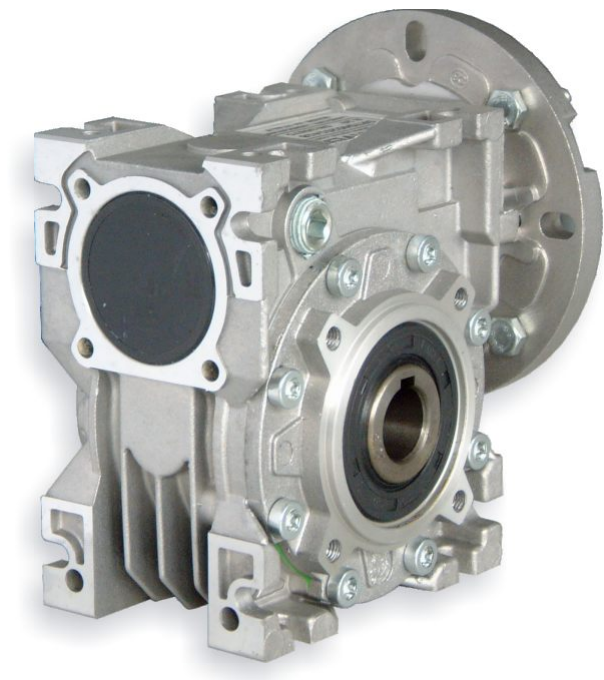

FRT 28 / 40 / 50

Worm gear box for esiMot

- Universal mounting facility
- Housing made of aluminium-diecast
- Hollow shaft output
- Backlash 20 arcmin
- Optional with solid axle output
- Flange for other motors on request
- Optional in ATEX95 design



FRT28

Admissible torque and efficiency

FRT28		2800 min ⁻¹		1400 min ⁻¹		900 min ⁻¹		700 min ⁻¹	
i	β	T _{2n}	η	T _{2n}	η	T _{2n}	η	T _{2n}	η
7	23°11'	13	0,86	18	0,84	22	0,82	23	0,81
10	16°41'	14	0,83	18	0,81	20	0,78	23	0,77
15	11°18'	14	0,79	18	0,77	21	0,72	22	0,71
20	10°23'	13	0,77	16	0,74	19	0,70	21	0,69
28	6°06'	15	0,69	20	0,66	22	0,61	24	0,60
40	5°14'	14	0,64	17	0,62	20	0,56	21	0,55
49	4°19'	13	0,61	17	0,57	19	0,52	20	0,51
56	3°03'	12	0,54	15	0,51	16	0,45	17	0,44
70	2°27'	11	0,49	12	0,45	13	0,43	13	0,40
80	2°37'	10	0,49	12	0,45	11	0,40	11	0,39
100	2°20'	7	0,46	8	0,43	8	0,37	8	0,36

i = ratio

β = Spiral angle

Self locking:

Spiral angle	β > 20°	20° > β > 10°	10° > β > 5°	5° > β > 3°	3° > β > 1°
Reversability	full	high	good	low	none
Self locking	none	none	low	good	full

Dimensions:

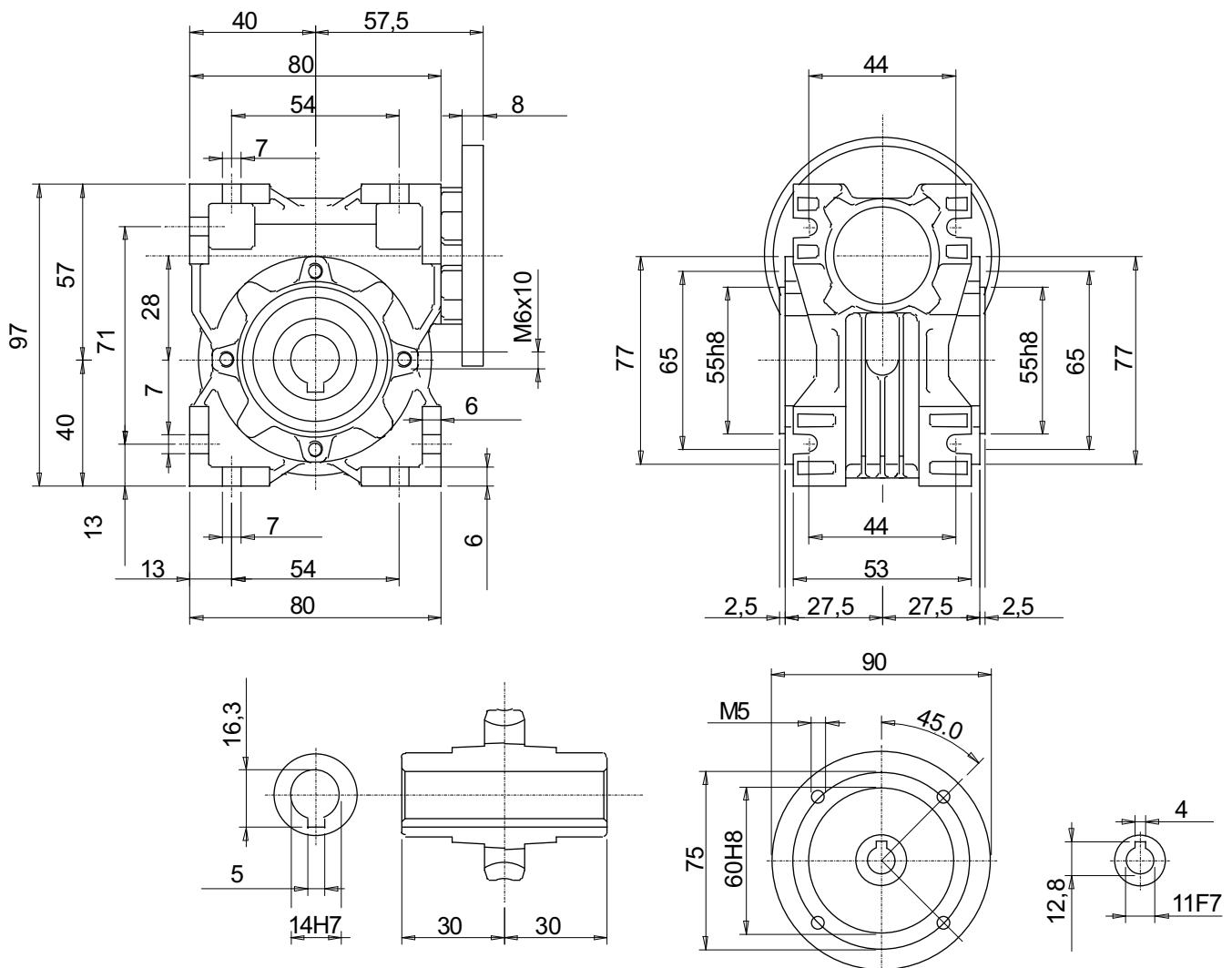

Gearbox output : AC 14

FRT40

Admissible torque and efficiency

FRT40		2800 min ⁻¹		1400 min ⁻¹		900 min ⁻¹		700 min ⁻¹	
i	β	T _{2n}	η	T _{2n}	η	T _{2n}	η	T _{2n}	η
5	30°57'	32	0,89	45	0,857	54	0,86	59	0,85
7	21°36'	31	0,87	45	0,85	52	0,83	58	0,82
10	16°41'	34	0,85	46	0,83	54	0,80	58	0,79
15	11°18'	34	0,81	44	0,78	52	0,74	58	0,73
20	8°31'	30	0,78	39	0,75	45	0,70	49	0,68
28	5°39'	34	0,72	48	0,68	52	0,63	55	0,59
40	4°17'	32	0,66	42	0,61	46	0,56	49	0,53
49	3°48'	31	0,62	41	0,58	43	0,52	46	0,51
56	3°25'	30	0,60	38	0,56	41	0,49	45	0,48
70	3°01'	29	0,57	36	0,52	40	0,46	43	0,44
80	2°51'	28	0,54	32	0,50	39	0,44	41	0,42
100	2°38'	26	0,51	29	0,46	36	0,2	38	0,39

i = Ratio

β = Spiral angle

Dimensions:

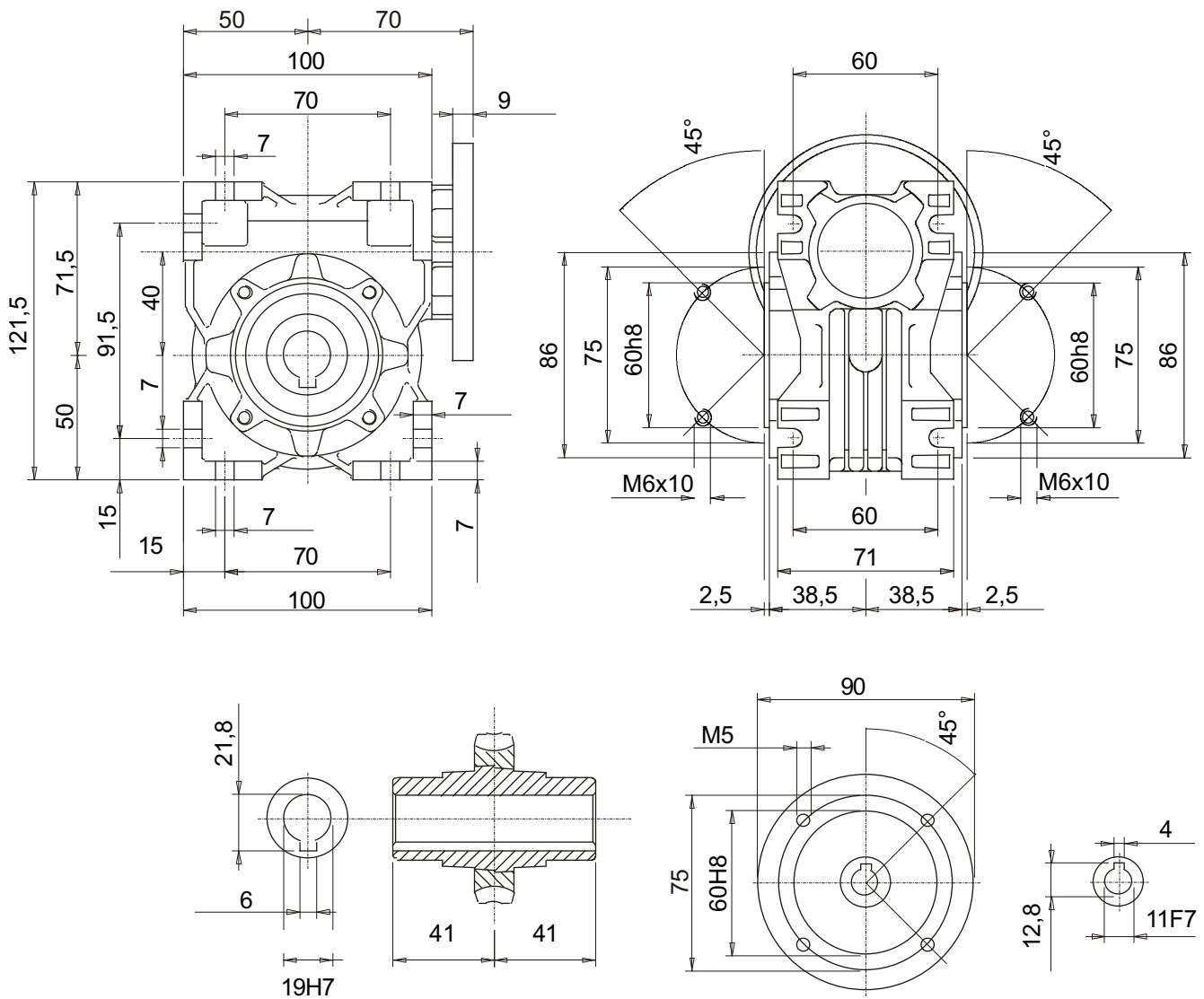

Gearbox output : AC 19

FRT50

Admissible torque and efficiency

FRT50		2800 min ⁻¹		1400 min ⁻¹		900 min ⁻¹		700 min ⁻¹	
i	β	T _{2n}	η	T _{2n}	η	T _{2n}	η	T _{2n}	η
5	30°57'	58	0,90	81	0,88	96	0,86	106	0,86
7	23°52'	62	0,88	75	0,86	95	0,85	110	0,83
10	16°41'	59	0,86	75	0,84	95	0,81	100	0,80
15	11°18'	61	0,82	74	0,78	91	0,76	99	0,75
20	8°59'	52	0,80	65	0,76	79	0,72	86	0,71
28	6°19'	66	0,75	85	0,71	99	0,65	106	0,64
40	4°31'	59	0,69	72	0,64	85	0,58	91	0,57
49	4°14'	56	0,66	76	0,62	81	0,56	87	0,54
56	3°42'	53	0,64	71	0,60	80	0,54	83	0,52
70	2°44'	46	0,58	63	0,53	67	0,47	70	0,45
80	2°51'	49	0,58	58	0,52	67	0,46	72	0,44
100	2°17'	40	0,52	43	0,47	55	0,42	62	0,39

i = Ratio

β = Spiral angle

Dimensions:

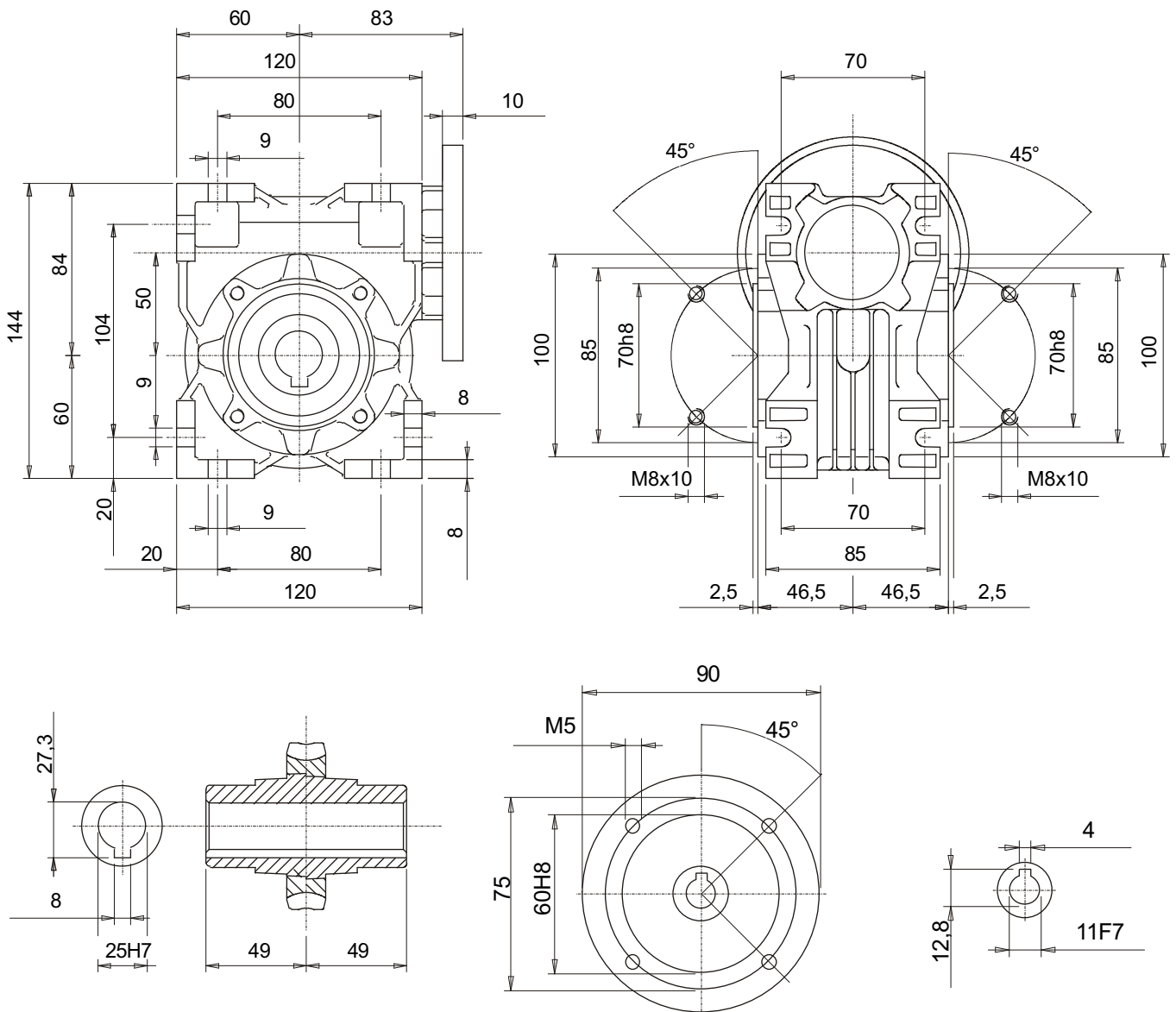

Gearbox output : AC 25

- SERVICE FACTORS FS = F1 • F2
for lifespan of 15.000h

F ₁	a	b	c	F ₂	d
3 - 4 h	0.8	1.0	1.5	6	1.0
8 - 10 h	1.0	1.2	1.8	60	1.2
10 - 24 h	1.4	1.6	2.0	120	1.4

a = Uniform load
b = Variable load
c = Shock load
d = Start/stops per hour

- WEIGHTS & LUBRICANTS

FRT	kg	l
28	1.1	0.03
40	2.5	0.08
50	3.8	0.13

- INPUT RADIAL LOADS R₁ [daN]

$$A_1 = 0.2 \times R_1$$

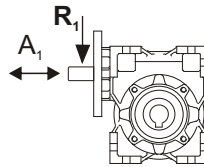

min ⁻¹	2800	1400	900	700	500	300
FRT 28	5	7	8	9	10	12
FRT 40	11	15	16	17	18	20
FRT 50	15	20	22	25	28	30

- RADIAL LOADS R₂ [daN] WITH STANDARD BEARINGS

$$A_2 = 0.2 \times R_2$$

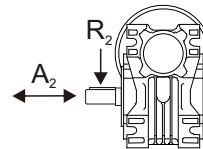

min ⁻¹	280	200	140	93	70	50	35	29	25	20	18	14	Brg.No.
FRT28	---	45	50	55	60	62	70	75	80	90	95	100	16005
FRT40	100	100	110	120	135	150	160	170	180	190	200	230	16006
FRT50	145	125	145	170	190	200	230	240	260	280	290	320	16008

- RADIAL LOADS R₂ [daN] WITH HEAVY DUTY BEARINGS

$$A_2 = 0.2 \times R_2$$

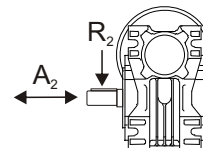

min ⁻¹	280	200	140	93	70	50	35	29	25	20	18	14	Brg. No.
FRT28	---	65	75	82	90	93	105	112	120	130	130	130	6005
FRT40	140	150	155	165	190	210	225	240	250	260	260	260	32006
FRT50	200	175	200	240	260	300	340	360	390	420	420	420	32008

Notes

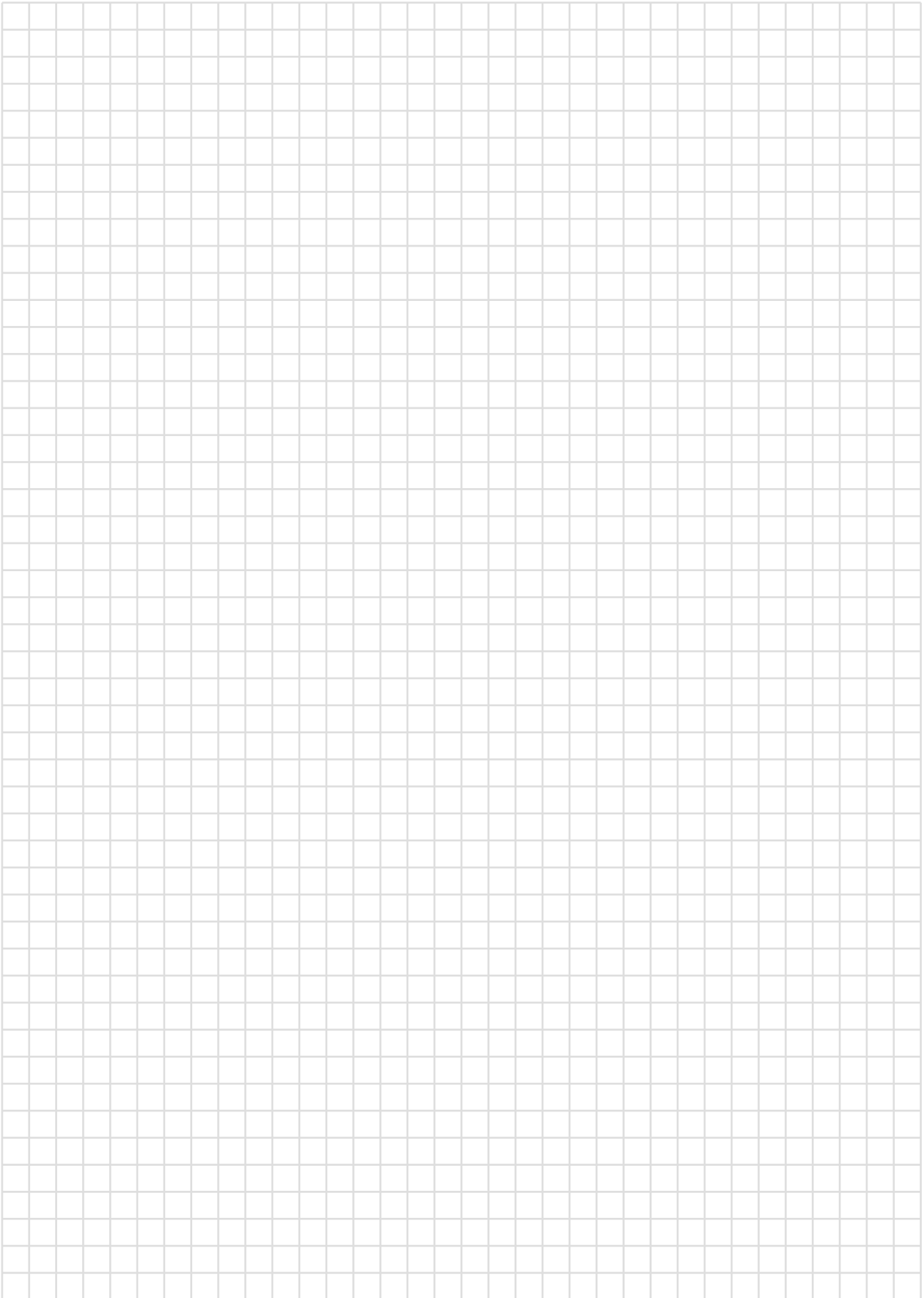

All data in this brochure have an informative character without warranty of characteristics. Changes without previous announcement reserved.

esitron-electronic GmbH

Ernst-Zimmermann-Str. 18
D-88045 Friedrichshafen
Internet: www.esitron.de

Tel. +49(0)7541-6000-0
Fax +49(0)7541-6000-11
E-Mail: info@esitron.de